

MULTIFUNCTION LABEL CUTTING AND FOLDING MACHINE



HSTC-HC-586 / HSTC-HC-586L / HSTC-HC-586S



The HSTC-HC-586 model is suitable for use as a dedication end fold, center fold and hanging fold machine. the use of end folding accounts for more than 50% of the market. every part of this machine has been modified to make it simple and convenient to use.

1. Three mode swappable label folding operation, mode can be changed by just exchanging the mould, A single person will be suitable to handle the easy and simple installation.
2. The HSTC-HC-586 model is easy to operate and has superb performance. It is designed easily for use with soft label and for its smooth operation. The most distinctive feature is the patent label length adjustment mechanism, which is easy to operate without the need for tools.



MULTIFUNCTION LABEL CUTTING AND FOLDING MACHINE

HSTC-HC-586 / HSTC-HC-586L / HSTC-HC-586S

SPECIFICATIONS

HSTC-HC-586S

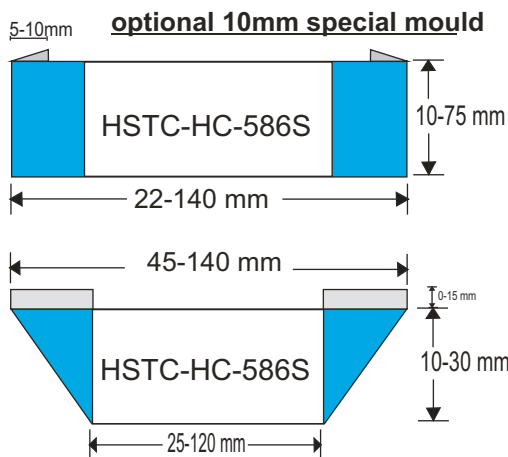

HSTC-HC-586

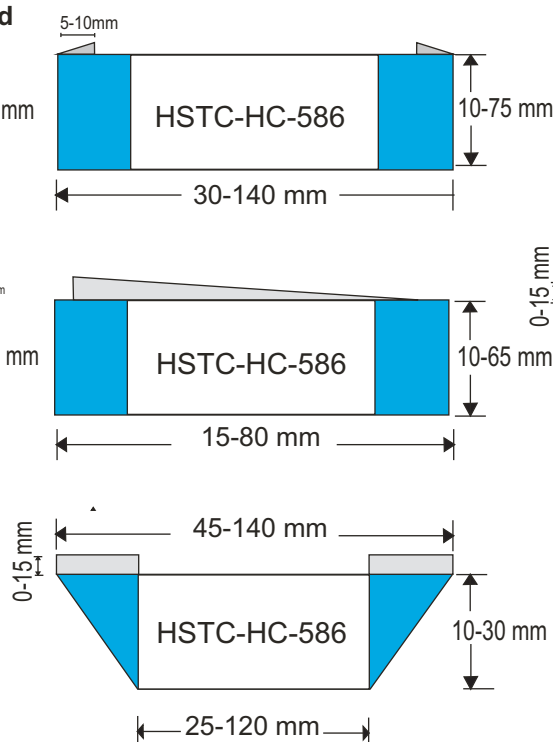

HSTC-HC-586L

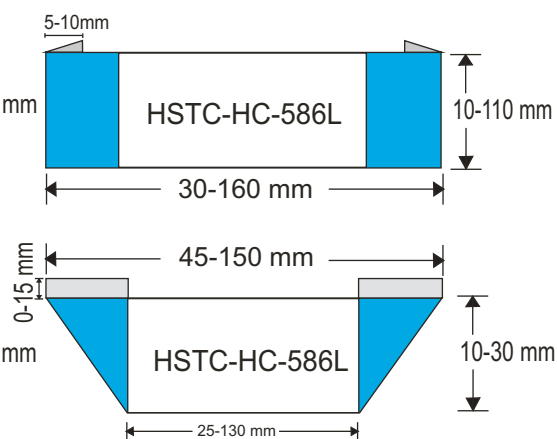

Dimension

1300 L x 1100 W x 1500 H mm

Weight

410 KG

Power

220 V - 110 V AC

HONG KONG SHANGHAI TRADING COMPANY

Block D, Flat D8, 7th Floor, 36-44,
Nathan Road, TST, Kowloon, HongKong
Tel. :- +852-98324807, 68509886. Fax. :- +852-23683344
Email Id :- info@hstchk.com
Web:- www.hstchk.com

Trust

Dependability

Service